



GLOBAL SERIES

Air-Operated Double Diaphragm Pumps

G25 ALUMINUM

40.1 GPM Maximum Flow Rate

1 inch Port Size

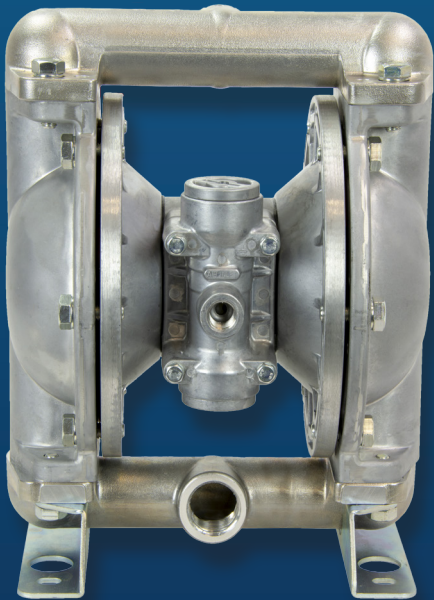

The genesis of a new era is upon us! Specializing in pneumatically driven equipment for decades, we have combined genius technology with next generation manufacturing, enabling us to produce the latest genre of high quality pumps. The Global Series is now available worldwide for general industrial market applications.

**ENGINEERED TO PERFORM.
DESIGN TO OUTLAST.®**

Technical Specifications

Max. Flow Rate	40.1 GPM
Port Size	1" Female NPT
Air Supply Pressure	20-100 PSI
Liquid Temperature	32-212°F
Max. Air Consumption	49.4 SCFM
Net Weight	20.3 lbs.
Max. Size Solid	1/8" (3mm)
Dimensions	8.27" L x 10.04 W x 12.44 H
Air Inlet	3/8" Female NPT
Body Material	Aluminum (ADC-12)
Max. Discharge Volume Per Cycle	0.158 Gallons

APPLICATIONS:





GLOBAL SERIES

Air-Operated Double Diaphragm Pumps

G25 ALUMINUM

Features & Benefits

- Truly non-lubricated (no grease pre-pack) / maintenance free air distribution system
- Stall Free / Ice Free operation
- Fewer Wearing Parts
- Ease of Repair - Quick teardown / Rebuild
- 20% less air consumption over competitor's pumps
- Piping interchangeability with leading brands

Elastomeric Options

- Buna N
- Santoprene®
- Hytrel®
- Viton®

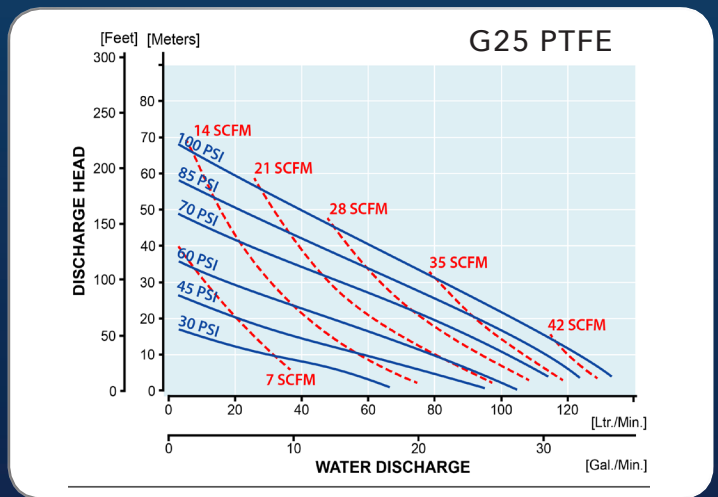
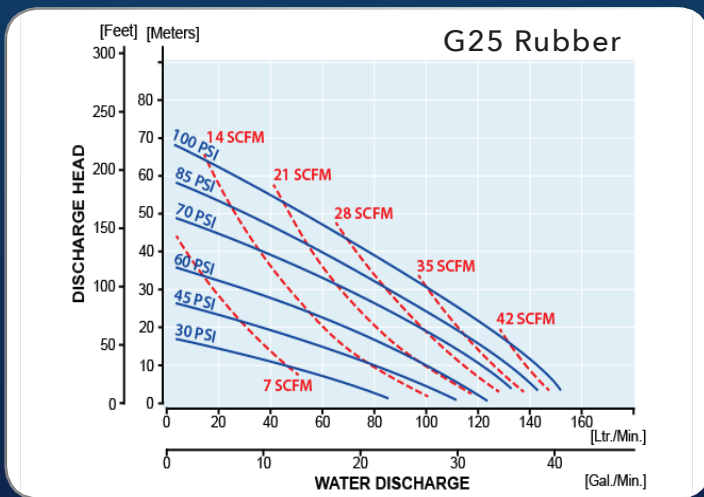
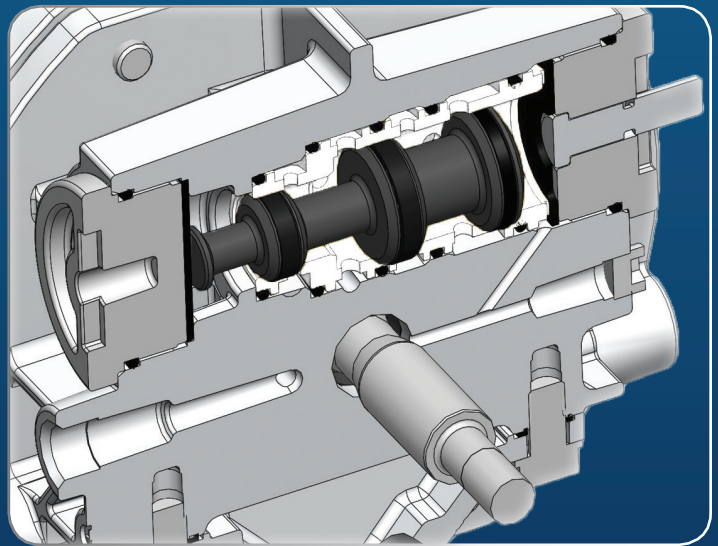

Toll Free: (800) 990-7867
www.yamadapump.com

Local Distributor:

Form# G25A0321

Hytrel® is a registered trademark of E.I. du Pont de Nemours and Company.
 Kynar® is a registered trademark of Arkema.
 Nordel™ is a trademark of DuPont Dow Elastomers.
 Santoprene® is a registered trademark of Monsanto Co.
 Viton® is a registered trademark of DuPont Performance Elastomers.
 Ekonol® is a registered trademark of Saint_Gobain Advanced Ceramics LLC.